



Jupiter

SINGLE & PARALLEL
FERMENTERS/
BIOREACTORS



SOLARIS
BIOTECH SOLUTIONS

SINGLE & PARALLEL FERMENTERS/BIOREACTORS

JUPITER

The **JUPITER** platform offers multiple autoclavable vessel sizes and designs from 2 up to 10 L total volume. Various aspect ratios are also available.

Additionally, the **JUPITER** platform offers the capability of pressure control in the 2 and 4 L volumes.

The system is highly configurable, built with high quality components, and offered at a competitive price with no strings attached.



JUPITER typical applications includes the following:

- Education & Basic research
- Scale-up and scale-down studies
- Process development and optimization

JUPITER can be used for:

- Biopharmaceutical
- Biofuels
- Food industry
- Bioremediation
- Bioplastic
- Cosmeceutical
- Nutraceutical

**WHY TO
INVEST
IN THIS PRODUCT**

The best ratio
**Quality/
Capability/Price**
on the market

Parallel control
up to 24 units

SINGLE & PARALLEL FERMENTERS/BIOREACTORS

JUPITER

Benefits

Jupiter 2.0 & 4.0:
Pressure controlled up to 1.6 bar
 Easier scaling up
 Higher oxygen transfer

Up to 24 units managed with one HMI with innovative PARALLEL process control LEONARDO: smart controller designed to provide a high level of automated management of the fermentation/cultivation processes
 Batch, Fed batch or continuous processes

Powerful/ Accurate **brushless motor**, from 1 to 2000 RPM.
 Online absorbed Torques (Nm) and Power (W) measurements obtaining an indirect density indication of the culture broth.



Modbus Digital sensors

LEDA safe sterile sampling system (only for atmospheric pressure vessels)

Safety: pressure relief valve included in each unit

Compact and modular PCS

Additional parameter in modular external boxes for future PCS upgrade including dCO₂, cell density, weight, peristaltic pumps, ect



N.4 assignable Watson Marlow pumps in entry level

Wide range of options, 5 different volumes and 2 different ratio H/D

Fully removable and cleanable glass jacket for an improved heat transfer during autoclaving



Different gas mixing strategies with up to 5 TMFC

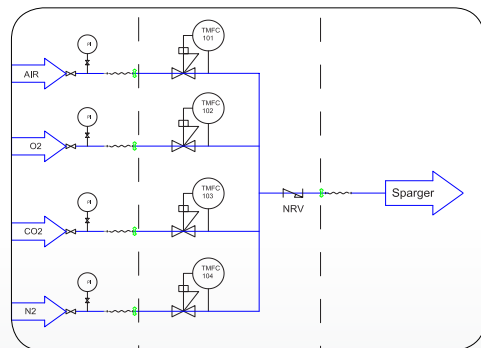

24" touch HMI

Remote access via PC, tablet/smartphone
 Remote control for after sale assistance





Modbus Digital sensors

Why a digital sensor?

Digital sensors (including Cell Density products) have been integrated to the Solaris PCS and Leonardo controlling software, giving the user many benefits over traditional analog sensor outputs. Such benefits include a robust communication protocol not susceptible to signal loss, in-software sensor diagnostic information, parallel calibration/batch calibrations and more.

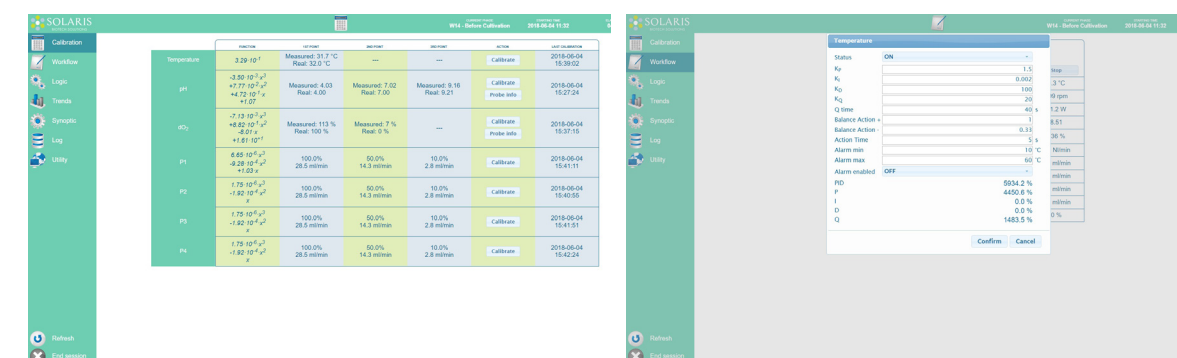

Sensor life traceability

Reducing background noise

GAS MIXING

Hardware and software adaptability are key to enable the best aeration strategy for each process. Thermal mass flow controllers (TMFC) allow precise flow rate control of individual gasses. Up to 5 TMFC's can be configured within each PCS cube and integrated to the controlling software. The powerful software and control platform allows precise cascade adjustment of multiple parameters to manage gas transfer, OTR, kLa, etc.

- n.1 TMFC included in "entry" level system; additional available as optional.
- Various agitator and baffle designs available
- Automatic gas mixing algorithms
- Toro, sintered and other spargers available



LEDA sterile sampling system

ONLY FOR ATMOSPHERIC PRERSSURE VESSELS

Technical specifications

Material	VALOX resin (external) silicone (internal)
Autoclavable	121-133°C (up to 30 minutes)
Residual volume	0.04 mL
Flow rate	165 mL/minute

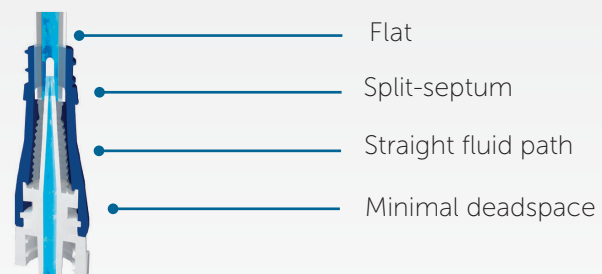

- Sterile single use sampling system up to 180 sterile sampling per batch.
- Needlefree connector is designed to reduce the risk of contamination during sampling.
- The sterile combination of a syringe (3-5-10-30 ml) and a non return valve guarantees the sterility after sampling until the next use

Smart PCS



Solaris new modular product design strategy decreases time to market and the number of unique parts in the product architecture, increasing the number of product variants. The result is a lean, flexible and smart PCS, which can be stacked in case of parallel processes through a dedicated support.



Additional parameters in modular external boxes for future PCS upgrade including dCO₂, Cell Density, Weight, Peristaltic pumps, ect.

Leonardo 3.0

USER-FRIENDLY SOFTWARE

Solaris controlling software offers a simply laid out, yet powerful platform for experimental design planning and process control. The graphical user interface enables the intuitive selection and adjustment of control functions. Extracted data is compatible with Window Excel but, in addition, Solaris offers a platform where fermentation data can be easily exported in real time and thus managed. This software is included in the supply and can be installed on an unlimited number of the client's PC or laptops.

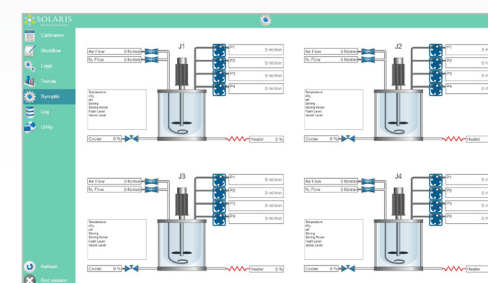

Do it parallel: smarter..faster

Leonardo allows intuitive and time-saving parallel operations. Up to 24 independent fermentations/cultivations can be carried out simultaneously.

Parallel synoptic.

Do it wireless!

Increase mobility: users have the option to access the platform remotely, via PC, tablet, phone. Remote access is multi-level password protected.

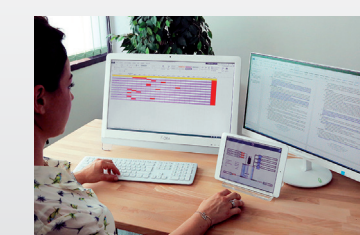
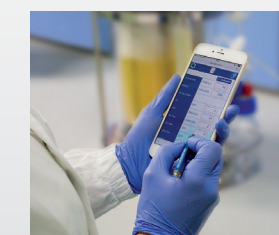

Data sheet

Vessel					
Solaris Code	Jupiter 2.0	Jupiter 4.0	Jupiter 6.5	Jupiter 8.0	Jupiter 10.0
Production Code	jpt110300	jpt130395	jpt160395	jpt160480	jpt180480
Total Volume (L)	2,00	4,00	6,50	8,00	10,00
Ratio D/H	1:3,0	1:3,0	1:2,5	1:3,0	1:3,0
Min. Working Volume (L)	0,35	0,60	1,10	1,10	1,60
Max. Working Volume (L)	1,40	2,80	4,50	5,50	7,0
Max. temperature	70°C				
Operating pressure	< 0,5 bar Jupiter 2.0 and 4.0: optionally < 1.6 bar				
Headplate Ports (n.10 in Jupiter 2.0; n.13 in the others)	10: n. 1 Agitation Group, n.1 Gas Sparger, n.1 Gas Overlay, n.1 Gas Out/Condenser, n.1 Sampling/Harvesting, n.1 Temperature, n.1 Multifeed. n.2 Sensors DN12, n.1 Spare. 13: n.1 Agitation Group, n.1 Gas Sparger, n.1 Gas Overlay, n.1 Gas Out/Condenser, n.1 Sampling/Harvesting, n.1 Sterile Sampling System, n.1 Temperature, n.1 Multifeed, n.2 Sensors DN12, n.3 Spare.				
Design	Borosilicate Glass Jacketed Vessel				
Materials	Borosilicate Glass and AISI 316 L				
Sensors length (mm)					
pH	325	425	425	425	425
dO ₂	325	425	425	425	425
Dimensions for autoclave (with Condenser)					
Height (mm)	610	705	705	790	790
Diameter (mm)	275	285	315	315	335
Stirring					
Drive	Brushless Motor				
Speed (rpm)	1-1900	1-1800	1-1700	1-1700	1-1700
Nominal Torque (Nm)	0,9	0,9	0,9	1,1	1,1
Impellers	Select from: Rushtons impellers, Marine Impellers, Pitched blade				
Thermoregulation					
Control	PID Control - Accuracy 0,1 °C - Jacketed with n. 2 Electric Cartridge Heaters and cooling valve				
Total Heater Power (W)	400	600	700	700	700
Gas Control & Gas Mixing					
Sparger and overlay Gas Control	TMFC				
Gas Mixing (Air,CO ₂ ,O ₂ ,N ₂)	n.1 TMFC (included in entry level) + n.4 solenoid valves or + n. of additional TMFC (up to n.4)				
Sparger type	Select from: Toro type (ring), sintered microbubbling - both provided with 0,22 µm sintered filter				
Gas Out	n. 1 Condenser + 0,22 µm sinterized filter				
Peristaltic Pumps					
	n.4 Watson Marlow type 114, fixed speed, max. 60 rpm, volumetric flow 0,5-51 ml/min, function assignable from software				
	(optional) Watson Marlow type 313 FDM/D, max. speed 350 rpm, volumetric flow 1,5-1750 ml/min, function assignable from software				
Controller					
Master Control Module	From 1 to 24 units - 35x37xh36 cm				
HMI with Leonardo software	Operate interface 58x15xh48 cm with 24" monitor				

Controls

INTEGRATED IN THE PCS	Temperature	
	Sensor	PT100
	Accuracy	0,1 °C
	Control system	Measuring resident in Leonardo 3.0 software
	Control range	0 - 70°C
	pH	
	Sensor	Digital sensor
	Sensitivity	57 to 59 mV/pH
	Control system	Measuring resident in Leonardo 3.0 software
	Control range	0 - 14
Operation temperature	0 - 130°C	
Pressure range	0 - 6 bar	
INTEGRATED IN THE PCS	dO ₂	
	Sensor	Digital Optical sensor
	Accuracy	±0.05%-vol, 21±0.2%-vol, 50±0.5%-vol
	Control system	Measuring resident in Leonardo 3.0 software
	Control range	0,05 - 300% air saturation
	Operation temperature	-10 - 130°C
	Pressure range	0 - 12 bar
	Antifoam/Level	
	Sensor	Solaris sensor
	Control	Measuring resident in Leonardo 3.0 software
INTEGRATED IN THE PCS	Redox (ORP)	
	Sensor	Digital sensor
	Sensitivity	57 to 59 mV/pH
	Control system	Measuring resident in Leonardo 3.0 software
	Control range	±2000 mV
	Operation temperature	-10 -130°C
	Pressure range	≤ 6 bar
	Conductivity	
	Sensor	Digital sensor
	Accuracy	±3%
Control system	Measuring resident in Leonardo 3.0 software	
Control range	1 - 3000 µS/cm	
Operation temperature	0 -130°C	
Pressure range	0 - 20 bar	
EXTERNAL MODULAR BOX	dCO ₂	
	Sensor	Analog sensor
	Accuracy	±10% (pCO ₂ 10-900 mbar) ≥ ±10%(pCO ₂ > 900 mbar))
	Control system	Measuring resident in Leonardo 3.0 software
	Control range	0,00-200% saturation
	Operation temperature	-20.0-150°C
	Cell density	
	Sensor	Digital sensor
	Accuracy	Mammalian cells in suspension ±5·10 ⁴ cells/ml - Fermentation ±0.05 g/l dry weight
	Control system	Measuring resident in Leonardo 3.0 software
Pressure range	0-3 bar (option 1) 0-10 bar (option 2)	
Operation temperature	0-60°C (option 1) 0-80°C (option 2) (max. sterilization temperature 135°C)	
Option 1	Dencytee: Total cell density based on turbidity (Two ranges: 10 ⁴ to 10 ⁸ mammalian cells/ml - 0.5 to 100 g/L dry weight)	
Option 2	Incyte: Viable cell density based on capacitance (Two ranges: 5x10 ⁴ to 8x10 ⁸ mammalian cells/ml - 5 to 200 g/L dry weight)	
EXTERNAL MODULAR BOX	Weight	
	Sensor	Digital balance
	Accuracy	±0.2 g
	Control	Measuring resident in Leonardo 3.0 software
Peristaltic pumps		
WM 114	10-60 rpm	

Chiller

- Optionally JUPITER can be equipped with a chiller for heat removal from your culture minimizing lab water usage
- Using this system you don't need a water supply line in your lab
- Cost-effective cooling of fermenters
- Easy operation
- Refregerant level monitoring



Chiller data sheet

Working temperature range	-10°C / +40°C
Temperature stability	±0.5
Power consumption	0.7 kW
Filling volume range	2-8 L
Cooling output at 20°C measured with ethanol	0.25-0.60 kW
Cooling output at 10°C measured with ethanol	0.20-0.50 kW
Cooling output at 0°C measured with ethanol	0.15-0.36 kW
Cooling output at -10°C measured with ethanol	0.09-0.15 kW
Pump pressure max.	0.35-1.30 bar
Pump flow max.	16-35 L/min.

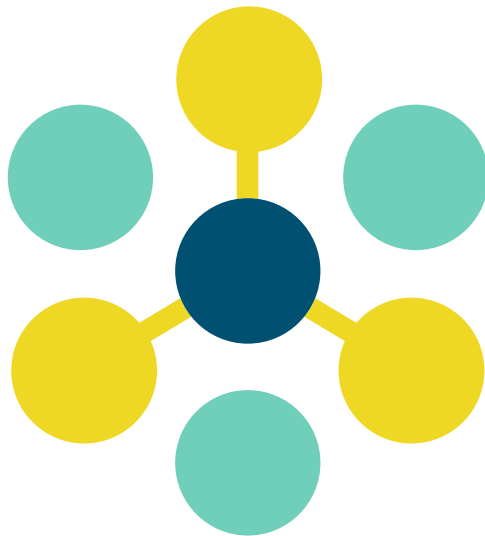

SOLARIS

BIOTECH SOLUTIONS

SOLARIS BIOTECHNOLOGY srl
Via Bachelet, 58 - 46047 Porto Mantovano
Mantova - Italy
Phone: +39 0376 408760
Fax: +39 0376 385108
Email: info@solarisbiotech.com
www.solarisbiotech.com